

972K

Wheel Loader



Engine

Engine Model	Cat® C9.3 ACERT™	
Max. Net Power (1,800 rpm) – ISO 9249	215 kW	288 hp
Max. Net Power (1,800 rpm) – SAE J1349	215 kW	288 hp

Buckets

Bucket Capacities	2.9 m ³ -9.9 m ³	3.75 yd ³ -13.0 yd ³
-------------------	--	--

Weights

Operating Weight	26 212 kg	57,770 lb
------------------	-----------	-----------

• For 4.8 m³ (6.3 yd³) general purpose buckets with bolt-on cutting edges.

972K Features

Performance Series Buckets

With standard Performance Series Buckets, operators benefit from reduced dig times and better material retention; ultimately translating into significant productivity and fuel efficiency improvements.

Load Sensing Hydraulics

Load sensing hydraulics produce flow and pressure for the implement system upon demand and only in amounts necessary to perform the needed work functions, enhancing machine productivity and fuel efficiency.

Operator Environment

The new four post ROPS cab provides enhanced comfort, visibility, and productivity resulting in a more efficient operator. New features include an ergonomic electro-hydraulic (EH) joystick steering system with position control and force feedback (speed sensitive), automatic climate control, viscous mounts to reduce noise and vibration levels, post mounted membrane switches, and a convex windshield giving the operator a panoramic view.

Cat® C9.3 ACERT™ Engine

The innovative Cat C9.3 ACERT engine is optimized for maximum fuel efficiency and increased power density while meeting Tier 4 Interim/Stage IIIB emission standards.

Powershift Transmission

The K Series™ transmissions incorporate a new shifting strategy that delivers smoother shifts, faster acceleration, and increased travel speed when climbing a grade.

Fuel Efficiency

The 972K wheel loader has been integrated as a system; from the linkage and work tool carrying the payload, to the engine, transmission and torque converter moving the machine, the system has been optimized to achieve the lowest cost per ton.

Contents

Reliability	3
Durability	4
Productivity	5
Versatility	6
Operator Environment	8
Serviceability	10
Sustainability	11
Customer Support	11
Owning Costs	12
Operating Costs	13
Wheel Loader Specifications	14
Standard and Optional Equipment	30



The Cat® 972K was designed to improve operator comfort, performance, and productivity, all while meeting Tier 4 Interim/Stage IIIB emission standards. The Performance Series Buckets enhance visibility and decrease cycle times. The unmatched, revolutionary world-class cab creates a comfortable, efficient, safe, and productive operator environment. The innovative Cat C9.3 ACERT engine is optimized for maximum fuel efficiency and increased power density while meeting Tier 4 Interim/Stage IIIB emission standards. The reliability, durability, and versatility of the 972K result in a machine that is better built to meet your needs. All day. Every day.

Reliability

Tested and Proven. Ready to Work.

Structures

The K Series™ features many of the components designed and proven reliable over generations of product design.

Strata Precleaner

The system removes 93% of the dust particles before the air has reached the primary engine air filter. As air enters the precleaner, stationary vanes cause the incoming air to spin. The resulting centrifugal force spins dust and dirt to the outer walls where they are ejected out into the exhaust stream, while the clean air flows down the center of the tube and continues into the primary air filter. The primary benefit is extended filter life.

Cold Start/High Altitude Package

A new optional cold start package includes a fan pump bypass, transmission pump bypass, additional battery capacity, and an engine heater plug/cord. The bypass systems reduce the parasitic load on the engine, while the additional battery capacity increases the cold cranking revolutions during startup. With the new optional cold start package available on K Series, starting capability has been dramatically improved in cold weather conditions. The system also improves starting capability at high altitudes.

Monitoring Programs

Monitoring product health is key to maintaining reliability of any equipment. Many programs offered by Caterpillar make the tracking of the customer's machine health quick and easy. These programs include Product Link, VisionLink™, and S·O·SSM Services.

Renowned Cat Dealer Support

From helping you choose the right machine to knowledgeable support, Cat dealers provide the best when it comes to sales and service. Manage costs with preventive maintenance programs like Scheduled Oil Sampling (S·O·SSM) analysis or elaborate Customer Support Agreements. Stay productive with best-in-class parts availability. Cat dealers can even help you with operator training to help boost your profits. And when it's time for machine rebuild, your Cat dealer can help you save even more with Genuine Cat Reman parts. Receive the same warranty and reliability as new products at cost savings of 40 to 70 percent for power train and hydraulic components.



Durability

Better Built to Meet Your Needs



Frames

The robotically welded two-piece structural frame design provides a rugged and reliable foundation for the machine that improves stability, performance, and serviceability. A robust articulating hitch system joins the front and rear frames improving durability. Enhanced lines routings across the hitch joint streamline the manufacturing process and improve reliability and durability.

Engine

The new Cat C9.3 ACERT engine was designed to optimize power density. It uses a combination of technologies to reduce regulated emissions while ensuring high performance and excellent fuel efficiency. An upgraded ADEM™ 4 electronic control module manages the combustion process and a new high-pressure common rail fuel system allows precise injection timing for a clean, efficient fuel burn. The rugged Cat Clean Emissions Module is securely rubber mounted on its own platform above the engine and contains a Diesel Oxidation Catalyst, Diesel Particulate Filter and Cat Regeneration System. Regeneration, the process by which soot is removed from the Diesel Particulate Filter, is completely automatic and does not interrupt the machine's work cycle.

Emissions

The 972K features a Cat C9.3 ACERT engine and a Cat Clean Emissions Module to deliver the performance and efficiency that customers demand, while meeting Tier 4 Interim/Stage IIIB emission standards. The six-cylinder electronic engine is turbocharged and aftercooled. ACERT™ Technology is a combination of building blocks that includes electronics, fuel systems, air management systems and aftertreatment components. The system is optimized based on engine size, the type of application and the geographic location in which it will work. The technologies are applied systematically and strategically to meet high customer expectations for productivity, fuel efficiency, reliability and service life.

Axles

The 972K axles are designed to handle extreme applications resulting in reliable performance and extended life. The front axle is rigidly mounted to the frame in order to withstand internal torque loads and still maintain support for the wheel loader. The rear axle can oscillate to ± 13 degrees helping to ensure all four wheels stay on the ground providing stability even in the roughest terrain.





Productivity

Move More. All Day. Every Day.

Z-bar Linkage

The proven Z-bar linkage with Performance Series Buckets offer excellent penetration into the pile, high breakout forces, good roll back angles, and faster dig times. The results are improved tire life, superior fuel efficiency, and exceptional production capabilities; all helping to enable a sustainable solution for your business.

Load Sensing Hydraulics

Load sensing hydraulics produce flow and pressure for the implement system upon demand and only in amounts necessary to perform the needed work functions, enhancing machine productivity and fuel efficiency. Implement controllability is improved through simultaneous implement operation and repeatable fine modulation, enabling greater operator comfort through ease of operation.

Ride Control

Ride control provides the operator with a smoother ride over rough terrain, enabling a more comfortable ride at higher speeds. The benefit is reduced cycle times, higher productivity and better fuel efficiency while performing load and carry applications. The system works by using an accumulator to dampen the linkage motion, acting as a shock absorber.

Torque Converter

The 972K torque converter has been optimized to improve fuel efficiency and deliver more power to the ground. The 10% increase to rimpull delivers a performance and fuel efficiency boost in all applications.

Transmission

The K series transmissions incorporate a new shifting strategy that delivers smoother shifts, faster acceleration, and better performance climbing a grade. When placing the transmission into forward gear, the machine will automatically start in second gear. With the further enhancement of a torque based 2 to 1 downshift, the downshift will only occur based on machine load. Owners and operators will fully benefit from utilizing the automatic 1-4 transmission mode, which results in lower fuel consumption and optimal machine performance.

Versatility

Work Tool Options to Meet Your Needs



Work Tools for Many Job Site Requirements

An extensive range of work tools and bucket styles are available for the 972K to customize the machine for your operation. The list includes: Performance Series Buckets; Specialty Buckets (Multipurpose, Side Dump, Waste Handling, Woodchip); Pallet Forks, Log and Lumber Forks, Rakes (with or without top clamps); and Plows (angle or V-style). Each is available either with pin on or quick coupler interface.

Performance Series Buckets: Load Easy, Fuel Efficient, Carry More

Performance Series Buckets utilize a system-based approach to balance bucket shape with the machine's linkage, weight, lift and tilt capacities. Operators benefit from reduced dig times and better material retention; ultimately translating into significant productivity and fuel efficiency improvements.

Lower Operating Costs

Performance Series Buckets feature a longer floor that easily digs through the pile and provides excellent visibility for the operators to see when the bucket is full. Less time digging in the pile results in lower fuel consumption and improved tire life. A unique spill guard protects the cab and linkage components from material overflow.

Higher Productivity

Performance Series Buckets achieve higher fill factors – ranging from 100% to 115% depending on the machine application and material type. The buckets feature optimized geometry with a bucket opening matched to the machine's linkage and incorporate a curved side profile to maximize material retention. The optimized design results in unsurpassed production capabilities.

Performance Series Bucket Styles

Performance Series Buckets are available for General Purpose, Material Handling, Rock and Coal style buckets.

Fusion Quick Coupler

Improved Machine Performance

Fusion™ is the patented wheel loader coupler system from Caterpillar. The Fusion Coupler System provides performance virtually identical to pin on – with all the flexibility of a quick coupler system. The Fusion Coupler sits back, close-in to the loader arms – minimizing offset and increasing the machine's performance.

No Loss of Performance

Imagine lifting a hundred pound box with your arms fully extended. Now imagine lifting that same load close to your body. That's the genius of Fusion: designed to integrate the work tool and the machine by pulling the coupler and tool closer in to the loader. As a result, the center of gravity is moved inward, towards the machine. This translates to increased lifting ability when compared to machines equipped with other coupler systems.

Unsurpassed Durability

An advanced wedging mechanism creates a tight, rattle-free fit. This patented lock up system eliminates play and wear – resulting in a long service life. Wedges pull the attachment tight to the machine in two directions – in and down. Constant hydraulic pressure on the coupler wedges compensate for wear, assuring a tight fit through the life of the coupler. Tight fit gives better tool control and increased productivity. Coupler durability is substantially increased over traditional couplers.

Enhanced Visibility

An open coupler frame design clears sight lines from the operator's seat, making it easier than ever before to engage and disengage attachments with certainty. Offset tines and other design changes to Fusion Pallet Forks, working in conjunction with the Fusion Coupler, enhance visibility substantially at ground level and truck bed height when compared to traditional coupler and fork combinations.

Common Interface Compatibility

The Fusion Coupler System gives Caterpillar customers one common interface – eliminating the need for many different couplers across the entire range of small and medium wheel loaders. This expanded machine compatibility not only allows one machine to use a range of work tools, but also allows one work tool to be picked up by machines of many different sizes.

The Fusion coupler interface is designed to work on 924 through 972 machines. Each machine will have its own optimal bucket and fork recommendations. However, cross-machine compatibility gives you additional flexibility and fleet options not found with any other wheel loader coupler.

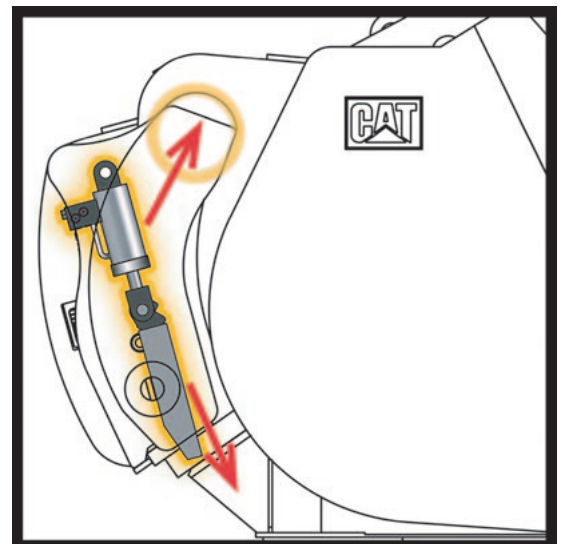
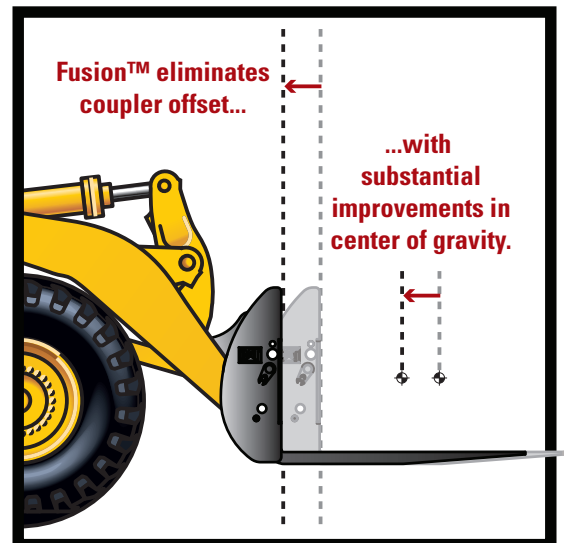

Operator Environment

Safe. Comfortable. Efficient.



Electro-Hydraulic (EH) Joystick Steering with Force Feedback (Speed Sensitive)

The industry leading EH joystick steering system combines operator comfort and precision control to provide a sustainable work environment for the operator. The system incorporates a force feedback motor that automatically adjusts the effort needed to tilt the ergonomic joystick based on ground speed, resulting in superior control in all applications and climates. For customers who prefer a steering wheel, an electro-hydraulic steering wheel is available as an option.

Implement Controls (EH)

Seat mounted single axis implement control levers provide the operator with precise control of the work tool, all while moving with the seat for maximum comfort. In cab programmable kick-outs and automatic cylinder snubbing maximize operator comfort and productivity throughout their shift. Optional implement joysticks are available for 2V and 3V hydraulics.

Seat

The Cat Optimized Seating System is 6-way adjustable to accommodate operators of all sizes. The seat has a one piece high back that supports the lumbar area of the back up through the shoulders. Both armrests are large and can be adjusted up, down, fore, and aft to enhance comfort and convenience. An optional feature for the cab seat is a heated backrest and cushion.

Sound and Vibration

New viscous cab mounts connect the cab to the frame of the machine, decreasing noise and vibration the operator is subjected to. This contributes to a well-rested operator, who remains efficient and productive. All Day. Every Day.

Information Display

The central display panel has a large text box, five analog-like gauges, and LED warning indicators. The large text box provides in-language information about machine operation, feature activation and system troubleshooting and calibration. With the 5 large analog-type gauges the operator can easily identify if key systems are within normal operating range. A resettable trip totals function has been incorporated to display information for average fuel consumed, total fuel consumed, idle fuel, idle time, operating hours, odometer, etc. The navigation buttons are located on the side of the screen and help assist with set up and other various functions.

Automatic Climate Control and Air Quality

The new climate control system automatically adjusts the air temperature and fan speed to maintain the operator's preferred climate setting. The cab air filtration system recirculates 90% of the cab air and is now serviced from outside the cab, enabling maximum air quality and cab cleanliness. The new air conditioning sealing system keeps refrigerant contained preventing system shutdown. Combined together, the operator remains efficient and productive all shift long due to a sustainable work environment.

Entry and Exit

Well-placed grab bars and a ladder inclination angle of 10-degrees forward makes the walk into the cab feel more like a staircase than a ladder. The new wider front hinged door can be opened and closed while seated, greatly improving ingress and egress. Two new left-hand and right-hand sliding windows can also be opened and closed with one hand while seated for comfortable communication to personnel on the ground.

Visibility

Visibility has been enhanced by removing the steering wheel, adding a convex windshield, and eliminating two cab posts. The cab has a clean and clear panoramic view for safe operation of the machine. External rearview mirrors are mounted on the cab to provide all around visibility. The external mirrors fold horizontally to provide fast, safe access to clean the window from the front platform. Optional heated and powered mirrors are available to further improve visibility in cold climates.

Rearview Camera

With the new standard rearview camera, visibility is greatly enhanced. The camera is located in a pocket on the grill to protect it from damage and the elements. The camera can be set to activate only when the transmission is in reverse to help eliminate distractions in the cab, especially when in dark environments. Two rear work lights are located in the rear grill and can be activated to illuminate the area behind the machine in low light conditions.

Control Panels and Park Brake Switch

Two control panels located on the front right ROPS post consist of large membrane switches making them easy to activate while wearing gloves. The membrane switches contain LED's to denote activation/mode and have a positive feel and "click" to signal activation. The ISO symbols located on each membrane switch are molded all the way through to ensure the image will not wear off over time. A new "help" feature explains the function of each membrane switch. A two position rocker switch activates the electro-hydraulic park brake and is automatically applied upon machine shutdown.



Serviceability

Easy to Maintain. Easy to Service.



Electrical Service Center

The electrical service center provides grouped ground level access to numerous electrical features, enhancing safety and convenience for operators and service technicians. It is conveniently located beneath the left platform for access before entering the cab and contains the maintenance free batteries, a fuse relay panel, main disconnect switch, ground level engine shutdown switch, hood tilt switch, and the jump start receptacle.

Engine Access

The K Series retains the Cat sloped “one-piece” tilting hood, which has become one of our brand’s hallmarks and provides industry-leading access to the engine, Cat Clean Emissions Module (CEM) and other components but with fresh new styling clearly distinct from the H Series. New to the loaders is a rear clamshell hood design that allows quick access to the engine oil dipstick and fill, fuel fill port, and cooler cores.

Cooling System

The cooling system is readily accessible for clean out and maintenance. With six cooling fins per inch and a perforated grill, most airborne debris entering the system passes through the cooler cores. The cooler cores swing out providing easy access for cleaning; an option variable pitch fan is available to automatically purge the cooler cores by periodically reversing the airflow.

Hydraulic Service Center

The hydraulic components are all conveniently located behind the hinged right side access ladder at a single ground level service center enhancing safety and reducing service time. Accessible from the service center are the transmission and hydraulic oil filters, brake accumulators, pressure test ports, etc.

Sustainability

Conserving Resources



The 972K is designed to compliment your business plan, reduce emissions and minimize the consumption of natural resources.

- Improved fuel efficiency – less fuel consumed results in lower emissions.
- Machine is built with a 96% recyclability rate (ISO 16714) to conserve valuable natural resources and further enhance machine end-of-life value.
- Engine air filter life doubled to reduce cost and waste.
- Improved operator efficiency through enhanced visibility and reduced noise/vibration levels.
- Product Link family of products and solutions that collect, communicate, store and deliver product and job-site information to maximize productivity and reduce costs.
- Major components are rebuildable, eliminating waste and saving money by giving the machine and/or major components a second – and even third – life.

Customer Support

Ready to Help. Anytime. Anywhere.

Machine Selection

Cat dealers are ready to help evaluate machine options; from new or used machine sales, to rental or rebuild options, Cat dealers can provide an optimal solution to meet customer business needs.

Product Support

Cat dealers are with customers every step of the way to maximize machine uptime by providing unsurpassed worldwide parts support, trained technicians and customer support agreements.

Operation

To help maximize the return on your investment, Cat dealers offer various training resources to improve operating techniques.

Financing

Cat dealers offer financing options to meet a variety of customer needs.



Owning Costs

Proven Best Investment



Customer Support Agreements

A Customer Support Agreement (CSA) is an arrangement between you and your Cat dealer that helps you lower your total cost per ton. CSAs are flexible, allowing them to be tailored to your business needs. They can range from simple Preventive Maintenance Kits to elaborate Total Cost Performance Guarantees. Having a CSA with your Cat dealer enables more time for you to do what you do best – run your business.

Monitoring Systems

Monitoring product health is key to optimizing the life of an investment into a Cat Wheel Loader.

- **Cat Product Link** – Cat Product Link allows remote monitoring of equipment to improve overall fleet-management effectiveness. Product Link is deeply integrated into machine systems. Events and diagnostic codes, as well as hours, fuel, idle time and other detailed information are transmitted to a secure web based application, VisionLink™. VisionLink includes powerful tools to convey information to users and dealers, including mapping, working and idle time, fuel level and more.
- **S.O.SSM Services** – Helps manage component life and decrease machine downtime, increasing productivity and efficiency. Regular fluid sampling can help track what is going on inside your machine. Wear related problems are predictable and easily repairable. Maintenance can be done to accommodate your schedule, resulting in increased uptime and flexibility in maintenance repairs before failure.

Parts Availability

Caterpillar provides an unsurpassed level of personalized service to help you work more cost effective and efficient. By utilizing a worldwide parts network Cat dealers help minimize machine downtime and save money by delivering replacement parts within 24 hours.

Resale Value

Owning quality equipment is an important factor in maintaining resale value. Caterpillar is not only known for machines that are better built, but provides product and dealer support to maintain the reliability and durability of your machine.



Operating Costs

Save Time and Money by Working Smart

Data from customer machines show Cat wheel loaders are among the most fuel efficient machines in the industry. Several features contribute to this excellent fuel efficiency:

- **Performance Series Buckets** – Deliver faster fill times and better material retention, ultimately reducing cycle times while improving productivity and fuel efficiency.
- **Load-Sensing Hydraulics** – Provides only the hydraulic flow required by the implement and steering systems for improved fuel efficiency and greater rimpull.
- **ACERT™ Engine** – Power dense engine enables a more fuel-efficient method to meet emissions regulations.
- **Fuel Management System (FMS)** – Optimizes power for maximum fuel savings with minimal impact on production.
- **Engine Idle Shutdown** – Automatic engine and electrical system shutdown conserves fuel.
- **Torque Converter** – Transfers more power to the ground and optimizes fuel efficiency in all applications.
- **Shift Strategy** – Reduced torque interruption increases driveline efficiency, conserving fuel. Auto 1-4 transmission mode keeps engine rpm low, reducing fuel consumption while delivering optimal machine performance.

Machine configuration, operator technique, and job site layout can impact fuel consumption by as much as 30 percent.

- **Machine Configuration** – Select the correct work tool and tire type based on machine application. Radial tires are preferred; ensure proper inflation pressures. Heavier tires burn more fuel. Keep engine rpm low by using auto 1-4 transmission mode.
- **Job Site Layout** – Spot loading targets in the right position. Avoid traveling more than twice the machine length during short cycle loading. Reduce transport distance for load and carry cycles by optimizing job site layout.
- **Loading Bucket** – Load in first gear and keep engine rpm low. Raise and tilt bucket smoothly and do not use a “pumping” motion. Avoid lift lever detent and use of transmission neutralizer.
- **Loading Truck or Hopper** – Do not raise the work tool any higher than necessary. Keep engine rpm low and unload in controlled manner.
- **Idle** – Set the parking brake to engage Engine Idle Management System.

972K Wheel Loader Specifications

Engine

Engine Model	Cat® C9.3 ACERT™	
Max. Gross Power (1,800 rpm) – SAE J1995	237 kW	318 hp
Max. Net Power (1,800 rpm) – ISO 9249	215 kW	288 hp
Max. Net Power (1,800 rpm) – SAE J1349	215 kW	288 hp
Max. Net Power (1,800 rpm) – EEC 80/1269	215 kW	288 hp
Peak Gross Torque (1,400 rpm) – SAE J1995	1426 N·m	1,051 ft-lb
Peak Net Torque (1,400 rpm) – SAE J1349	1335 N·m	985 ft-lb
Bore	115 mm	4.5 in
Stroke	149 mm	5.9 in
Displacement	9.3 L	568 in ³

- Cat engine with ACERT™ Technology – meets Tier 4 Interim/Stage IIIB emission standards.

Weights

Operating Weight	26 212 kg	57,770 lb
------------------	-----------	-----------

- For 4.8 m³ (6.3 yd³) general purpose buckets with BOCE.

Buckets

Bucket Capacities	2.90 m ³ - 9.90 m ³	3.75 yd ³ - 13.00 yd ³
-------------------	--	---

- Refer to bucket selection chart.

Operating Specifications

Static Tipping Load Full 37° Turn – ISO 14397-1*	16 317 kg	35,963 lb
Static Tipping Load Full 37° Turn – Rigid Tires**	17 642 kg	38,884 lb
Breakout Force	196 kN	44,075 lb

- For 4.8 m³ (6.3 yd³) general purpose buckets with BOCE.
- * Full compliance to ISO (2007) 14397-1 Sections 1 thru 6, which requires 2% verification between calculations and testing.
- ** Compliance to ISO (2007) 14397-1 Sections 1 thru 5.

Transmission

Forward 1	7.0 km/h	4.4 mph
Forward 2	12.5 km/h	7.8 mph
Forward 3	21.4 km/h	13.3 mph
Forward 4	36.9 km/h	22.9 mph
Reverse 1	8.0 km/h	5.0 mph
Reverse 2	14.3 km/h	8.9 mph
Reverse 3	24.5 km/h	15.2 mph
Reverse 4	42.2 km/h	26.2 mph

- Maximum travel speed in standard vehicle with empty bucket and standard L3 tires with 826 mm (33 in) roll radius.

Hydraulic System

Steering System Pump Type	Piston
Implement System – Maximum Pump Output (2,275 rpm)	340 L/min 90 gal/min
Implement System – Maximum Operating Pressure	31 000 kPa 4,496 psi
Implement System – Optional 3rd Function Maximum Flow	300 L/min 79.3 gal/min
Implement System – Optional 3rd Function Maximum Pressure	20 700 kPa 3,000 psi
Hydraulic Cycle Time – Raise from Carry Position	5.9 Seconds
Hydraulic Cycle Time – Dump at Maximum Raise	2.0 Seconds
Hydraulic Cycle Time – Lower, Empty, Float Down	2.4 Seconds
Hydraulic Cycle Time – Total	10.3 Seconds

- Cycle time with rated payload.

Brakes

Brakes	Meet OSHA, SAE J1473 OCT90 and ISO 3450-1985 required standards
--------	---

Axles

Front	Fixed	
Rear	Oscillating ±13 degrees	
Maximum Single-Wheel Rise and Fall	495 mm	19.5 in

Tires

- Choose from a variety of tires to match your application.
- Choices include:
 - 26.5R25 VLT BS E3 Radial
 - 26.5R25 VJT BS E3/L3 Radial
 - 26.5R25 VMT BS L3 Radial
 - 26.5-25 SRG LD FS L3 Bias
 - 750/65R25 XLD L3T MX L3 Radial
 - 26.5R25 XHA2 MX L3 Radial
 - 26.5R25 XLD D1 MX L4 Radial
 - 26.5R25 VSNT BS E4/L4 Radial
 - 26.5-25 SDT LD FS L5 Bias
 - 26.5R25 VSDL BS L5 Radial
 - 26.5R25 XLDD2 MX L5 Radial
 - 26.5R25 X MINE D2 MX L5 Radial
- NOTE: In certain applications (such as load and carry), the loader's productive capabilities might exceed the tires' tonnes-km/h (ton-mph) capabilities. Caterpillar recommends that you consult a tire supplier to evaluate all conditions before selecting a tire model. Other special tires are available on request.

Cab

- | | |
|-----------|-----------------------------|
| ROPS/FOPS | Meets SAE and ISO standards |
|-----------|-----------------------------|
- Caterpillar cab with a four post integrated Rollover Protective Structure (ROPS) are standard in North America and Europe.
 - ROPS meets SAE J1040 APR88 and ISO 3471:1994 criteria.
 - Falling Objects Protective Structure (FOPS) meets SAE J231 JAN81 and ISO:1992 Level II criteria.

Sound

- The sound values indicated below are for specific operating conditions only. Machine and operator sound levels will vary at different engine and/or cooling fan speeds. Hearing protection may be needed when the machine is operated with a cabin that is not properly maintained, or when the doors and/or windows are open for extended periods or in a noisy environment.
- The operator sound pressure level for a standard machine configuration, measured according to the procedures specified in ISO 6396:2008, is 71 dB(A) with the cooling fan speed set at maximum value.
- The machine sound power level for a standard machine configuration, measured according to the procedures specified in ISO 6395:2008, is 111 dB(A) with the cooling fan speed set at maximum value.
- The machine sound pressure level for a standard machine configuration, measured according to the procedures specified in SAE J88:2006, is 76 dB(A). The measurement was conducted under the following conditions: distance of 15 m (49.2 ft), moving forward in an intermediate gear ratio, static hydraulic cycle (with no payload) and with the cooling fan speed set at maximum value.
- The operator sound pressure level for a machine installed with a Low Sound package, measured according to the procedures specified in ISO 6396:2008, is 69 dB(A) with the cooling fan speed set at maximum value.
- The machine sound power level for a machine installed with a Low Sound package, measured according to the procedures specified in ISO 6396:2008, is 108 dB(A) with the cooling fan speed set at maximum value.

Service Refill Capacities

Fuel Tank – Standard	381 L	101 gal
Cooling System	66 L	17.4 gal
Crankcase	24.5 L	6.5 gal
Transmission	50 L	13.2 gal
Differentials and Final Drives – Front	64 L	16.9 gal
Differentials and Final Drives – Rear	64 L	16.9 gal
Hydraulic Tank	198 L	52.3 gal

972K Wheel Loader Specifications

Dimensions

All dimensions are approximate and based on L3 Michelin XHA2 tires.

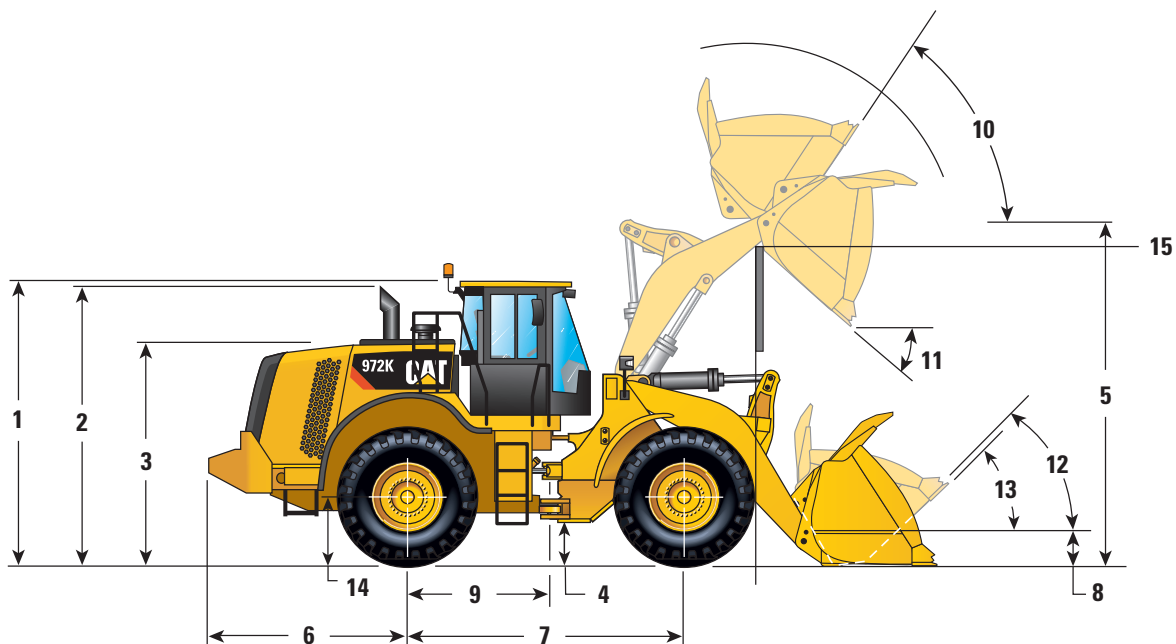

1	Height to Top of ROPS	3547 mm	11'7"
2	Height to Top of Exhaust Pipe	3518 mm	11'6"
3	Height to Top of Hood	2828 mm	9'3"
4	Ground Clearance with 26.5R25 (See Tire Option Chart for Other Tires)	475 mm	1'6"
5	B-Pin Height – Standard	4456 mm	14'7"
	B-Pin Height – High Lift	4792 mm	15'8"
6	Center Line of Rear Axle to Edge of Counterweight	2473 mm	8'1"
7	Wheelbase	3450 mm	11'3"
8	B-Pin Height @ Carry – Standard	689 mm	2'3"
9	Center Line of Rear Axle to Hitch	1725 mm	5'7"
10	Rack Back @ Maximum Lift	56 degrees	
11	Dump Angle @ Maximum Lift	48 degrees	
12	Rack Back @ Carry	50 degrees	
13	Rack Back @ Ground	41 degrees	
14	Height to Center Line of Axle	798 mm	2'7"
15	Lift Arm Clearance	3804 mm	12'6"
	Lift Arm Clearance @ High Lift	4153 mm	13'6"

Operating Specifications

Bucket Type		General Purpose – Pin On					
		Bolt-On Edges	Teeth and Segments	Teeth	Bolt-On Edges	Teeth and Segments	Teeth
Capacity – Rated (§)	m ³	4.20	4.20	4.00	4.40	4.40	4.20
	yd ³	5.49	5.49	5.23	5.75	5.75	5.49
Capacity – Struck (§)	m ³	3.70	3.70	3.50	3.80	3.80	3.60
	yd ³	4.84	4.84	4.58	4.97	4.97	4.71
Width (§)	mm	3220	3271	3271	3220	3271	3271
	ft/in	10'6"	10'8"	10'8"	10'6"	10'8"	10'8"
Dump Clearance at Maximum Lift and 45° Discharge (§)	mm	3225	3071	3071	3229	3076	3076
	ft/in	10'6"	10'0"	10'0"	10'7"	10'1"	10'1"
Reach at Maximum Lift and 45° Discharge (§)	mm	1332	1470	1470	1327	1465	1465
	ft/in	4'4"	4'9"	4'9"	4'4"	4'9"	4'9"
Reach at Level Lift Arm and Bucket Level (§)	mm	2955	3160	3160	2948	3153	3153
	ft/in	9'8"	10'4"	10'4"	9'8"	10'4"	10'4"
Digging Depth (§)	mm	103	103	73	103	103	73
	ft/in	4"	4"	2.8"	4"	4"	2.8"
Overall Length	mm	9129	9353	9353	9122	9346	9346
	ft/in	30'0"	30'9"	30'9"	30'0"	30'8"	30'8"
Overall Height with Bucket at Maximum Lift	mm	5937	5937	5937	6230	6230	6230
	ft/in	19'6"	19'6"	19'6"	20'6"	20'6"	20'6"
Loader Clearance Circle with Bucket at Carry Position (§)	mm	14 925	15 104	15 104	14 921	15 100	15 100
	ft/in	49'0"	49'7"	49'7"	49'0"	49'7"	49'7"
Static Tipping Load, Straight (ISO)*	kg	18 770	18 589	18 840	18 817	18 636	18 885
	lb	41,371	40,971	41,523	41,474	41,074	41,622
Static Tipping Load, Straight (Rigid Tire)*	kg	20 088	19 903	20 157	20 147	19 962	20 215
	lb	44,274	43,866	44,427	44,405	43,996	44,554
Static Tipping Load, Articulated (ISO)*	kg	16 396	16 213	16 447	16 437	16 253	16 485
	lb	36,138	35,734	36,251	36,227	35,822	36,334
Static Tipping Load, Articulated (Rigid Tire)*	kg	17 706	17 521	17 757	17 758	17 573	17 807
	lb	39,024	38,616	39,138	39,140	38,731	39,248
Breakout Force** (§)	kN	210	208	223	211	209	224
	lb	47,189	46,880	50,138	47,419	47,109	50,397
Operating Weight*	kg	26 223	26 361	26 198	26 229	26 367	26 203
	lb	57,795	58,099	57,740	57,807	58,111	57,752

* Static tipping loads and operating weights shown are based on a machine configuration with Michelin 26.5R25 XHA2 L3 Radial tires, full fluids, operator, standard counterweight, cold start, roading fenders, Product Link, open differential axles (front/rear), power train guard, secondary steering, and sound suppression.

** Measured 102 mm (4") behind tip of cutting edge with bucket hinge pin as pivot point in accordance with SAE J732C.

*** Rock bucket specifications are given on Michelin 26.5R25 XLDD2 L5 Radial tires.

(§) Specifications and ratings conform to all applicable standards recommended by the Society of Automotive Engineers, including SAE Standard J732C governing loader ratings.

(ISO) Full compliance to ISO 14397-1 (2007) Sections 1 thru 6, which requires 2% verification between calculations and testing.

(Rigid Tire) Compliance to ISO 14397-1 (2007) Sections 1 thru 5.

972K Wheel Loader Specifications

Operating Specifications

Bucket Type		General Purpose – Pin On					
		Bolt-On Edges	Teeth and Segments	Teeth	Bolt-On Edges	Teeth and Segments	Teeth
Capacity – Rated (§)	m ³	4.60	4.60	4.40	4.80	4.80	4.60
	yd ³	6.02	6.02	5.75	6.28	6.28	6.02
Capacity – Struck (§)	m ³	4.00	4.00	3.80	4.10	4.10	3.90
	yd ³	5.23	5.23	4.97	5.36	5.36	5.10
Width (§)	mm	3220	3271	3271	3220	3271	3271
	ft/in	10'6"	10'8"	10'8"	10'6"	10'8"	10'8"
Dump Clearance at Maximum Lift and 45° Discharge (§)	mm	3187	3033	3033	3154	2999	2999
	ft/in	10'5"	9'11"	9'11"	10'4"	9'10"	9'10"
Reach at Maximum Lift and 45° Discharge (§)	mm	1363	1500	1500	1392	1528	1528
	ft/in	4'5"	4'11"	4'11"	4'6"	5'0"	5'0"
Reach at Level Lift Arm and Bucket Level (§)	mm	3004	3209	3209	3049	3254	3254
	ft/in	9'10"	10'6"	10'6"	10'0"	10'8"	10'8"
Digging Depth (§)	mm	103	103	73	103	103	73
	ft/in	4"	4"	2.8"	4"	4"	2.8"
Overall Length	mm	9178	9402	9402	9223	9447	9447
	ft/in	30'2"	30'11"	30'11"	30'4"	31'0"	31'0"
Overall Height with Bucket at Maximum Lift	mm	6195	6195	6195	6031	6031	6031
	ft/in	20'4"	20'4"	20'4"	19'10"	19'10"	19'10"
Loader Clearance Circle with Bucket at Carry Position (§)	mm	14 951	15 132	15 132	14 976	15 157	15 157
	ft/in	49'1"	49'8"	49'8"	49'2"	49'9"	49'9"
Static Tipping Load, Straight (ISO)*	kg	18 658	18 476	18 733	18 683	18 500	20 705
	lb	41,124	40,722	41,288	41,179	40,775	45,634
Static Tipping Load, Straight (Rigid Tire)*	kg	19 985	19 799	20 059	20 017	19 830	22 448
	lb	44,048	43,638	44,210	44,118	43,705	49,475
Static Tipping Load, Articulated (ISO)*	kg	16 289	16 104	16 343	16 317	16 132	18 062
	lb	35,901	35,494	36,021	35,963	35,554	39,810
Static Tipping Load, Articulated (Rigid Tire)*	kg	17 608	17 422	17 662	17 642	17 455	19 773
	lb	38,808	38,398	38,927	38,884	38,471	43,580
Breakout Force** (§)	kN	202	201	214	196	194	207
	lb	45,482	45,173	48,227	44,075	43,766	46,655
Operating Weight*	kg	26 284	26 422	26 258	26 212	26 350	26 186
	lb	57,929	58,233	57,873	57,770	58,074	57,714

* Static tipping loads and operating weights shown are based on a machine configuration with Michelin 26.5R25 XHA2 L3 Radial tires, full fluids, operator, standard counterweight, cold start, roading fenders, Product Link, open differential axles (front/rear), power train guard, secondary steering, and sound suppression.

** Measured 102 mm (4") behind tip of cutting edge with bucket hinge pin as pivot point in accordance with SAE J732C.

*** Rock bucket specifications are given on Michelin 26.5R25 XLDD2 L5 Radial tires.

(§) Specifications and ratings conform to all applicable standards recommended by the Society of Automotive Engineers, including SAE Standard J732C governing loader ratings.

(ISO) Full compliance to ISO 14397-1 (2007) Sections 1 thru 6, which requires 2% verification between calculations and testing.

(Rigid Tire) Compliance to ISO 14397-1 (2007) Sections 1 thru 5.

Operating Specifications

Bucket Type		General Purpose – Pin On			General Purpose – Fusion QC		
		Bolt-On Edges	Teeth and Segments	Teeth	Bolt-On Edges	Teeth and Segments	Teeth
Capacity – Rated (§)	m ³	5.00	5.00	4.80	4.20	4.20	4.00
	yd ³	6.54	6.54	6.28	5.49	5.49	5.23
Capacity – Struck (§)	m ³	4.30	4.30	4.10	3.70	3.70	3.50
	yd ³	5.62	5.62	5.36	4.84	4.84	4.58
Width (§)	mm	3220	3271	3271	3220	3271	3271
	ft/in	10'6"	10'8"	10'8"	10'6"	10'8"	10'8"
Dump Clearance at Maximum Lift and 45° Discharge (§)	mm	3137	2982	2982	3195	3041	3041
	ft/in	10'3"	9'9"	9'9"	10'5"	9'11"	9'11"
Reach at Maximum Lift and 45° Discharge (§)	mm	1407	1543	1543	1367	1504	1504
	ft/in	4'7"	5'0"	5'0"	4'5"	4'11"	4'11"
Reach at Level Lift Arm and Bucket Level (§)	mm	3072	3277	3277	3000	3205	3205
	ft/in	10'0"	10'9"	10'9"	9'10"	10'6"	10'6"
Digging Depth (§)	mm	103	103	73	103	103	73
	ft/in	4"	4"	2.8"	4"	4"	2.8"
Overall Length	mm	9246	9470	9470	9175	9398	9398
	ft/in	30'4"	31'1"	31'1"	30'2"	30'10"	30'10"
Overall Height with Bucket at Maximum Lift	mm	6284	6284	6284	6036	6036	6036
	ft/in	20'8"	20'8"	20'8"	19'10"	19'10"	19'10"
Loader Clearance Circle with Bucket at Carry Position (§)	mm	14 989	15 170	15 170	14 944	15 126	15 126
	ft/in	49'3"	49'10"	49'10"	49'1"	49'8"	49'8"
Static Tipping Load, Straight (ISO)*	kg	18 779	18 595	18 832	18 260	18 079	18 430
	lb	41,390	40,984	41,507	40,246	39,848	40,621
Static Tipping Load, Straight (Rigid Tire)*	kg	20 115	19 927	20 166	19 563	19 379	19 746
	lb	44,334	43,919	44,447	43,118	42,711	43,520
Static Tipping Load, Articulated (ISO)*	kg	16 414	16 228	16 449	15 906	15 723	16 058
	lb	36,177	35,767	36,254	35,057	34,653	35,393
Static Tipping Load, Articulated (Rigid Tire)*	kg	17 739	17 551	17 772	17 205	17 020	17 369
	lb	39,097	38,683	39,171	37,920	37,513	38,282
Breakout Force** (§)	kN	198	197	210	203	201	215
	lb	44,634	44,325	47,205	45,615	45,306	48,375
Operating Weight*	kg	26 325	26 463	26 299	26 600	26 738	26 574
	lb	58,019	58,323	57,963	58,625	58,929	58,569

* Static tipping loads and operating weights shown are based on a machine configuration with Michelin 26.5R25 XHA2 L3 Radial tires, full fluids, operator, standard counterweight, cold start, roading fenders, Product Link, open differential axles (front/rear), power train guard, secondary steering, and sound suppression.

** Measured 102 mm (4") behind tip of cutting edge with bucket hinge pin as pivot point in accordance with SAE J732C.

*** Rock bucket specifications are given on Michelin 26.5R25 XLDD2 L5 Radial tires.

(§) Specifications and ratings conform to all applicable standards recommended by the Society of Automotive Engineers, including SAE Standard J732C governing loader ratings.

(ISO) Full compliance to ISO 14397-1 (2007) Sections 1 thru 6, which requires 2% verification between calculations and testing.

(Rigid Tire) Compliance to ISO 14397-1 (2007) Sections 1 thru 5.

972K Wheel Loader Specifications

Operating Specifications

Bucket Type		General Purpose – Fusion QC					
		Bolt-On Edges	Teeth and Segments	Teeth	Bolt-On Edges	Teeth and Segments	Teeth
Capacity – Rated (§)	m ³	4.40	4.40	4.20	4.60	4.60	4.40
	yd ³	5.75	5.75	5.49	6.02	6.02	5.75
Capacity – Struck (§)	m ³	3.80	3.80	3.60	4.00	4.00	3.80
	yd ³	4.97	4.97	4.71	5.23	5.23	4.97
Width (§)	mm	3220	3271	3271	3220	3271	3271
	ft/in	10'6"	10'8"	10'8"	10'6"	10'8"	10'8"
Dump Clearance at Maximum Lift and 45° Discharge (§)	mm	3200	3047	3047	3157	3003	3003
	ft/in	10'6"	9'11"	9'11"	10'4"	9'10"	9'10"
Reach at Maximum Lift and 45° Discharge (§)	mm	1362	1500	1500	1397	1535	1535
	ft/in	4'5"	4'11"	4'11"	4'7"	5'0"	5'0"
Reach at Level Lift Arm and Bucket Level (§)	mm	2993	3198	3198	3050	3255	3255
	ft/in	9'9"	10'5"	10'5"	10'0"	10'8"	10'8"
Digging Depth (§)	mm	103	103	73	103	103	73
	ft/in	4"	4"	2.8"	4"	4"	2.8"
Overall Length	mm	9167	9391	9391	9224	9448	9448
	ft/in	30'1"	30'10"	30'10"	30'4"	31'0"	31'0"
Overall Height with Bucket at Maximum Lift	mm	6205	6205	6205	6211	6211	6211
	ft/in	20'5"	20'5"	20'5"	20'5"	20'5"	20'5"
Loader Clearance Circle with Bucket at Carry Position (§)	mm	14 940	15 122	15 122	14 971	15 154	15 154
	ft/in	49'1"	49'8"	49'8"	49'2"	49'9"	49'9"
Static Tipping Load, Straight (ISO)*	kg	18 263	18 082	18 439	18 113	17 931	18 282
	lb	40,252	39,853	40,639	39,921	39,520	40,293
Static Tipping Load, Straight (Rigid Tire)*	kg	19 578	19 393	19 767	19 425	19 239	19 606
	lb	43,150	42,742	43,566	42,812	42,403	43,212
Static Tipping Load, Articulated (ISO)*	kg	15 902	15 719	16 060	15 761	15 577	15 912
	lb	35,049	34,645	35,396	34,738	34,332	35,072
Static Tipping Load, Articulated (Rigid Tire)*	kg	17 213	17 028	17 383	17 070	16 884	17 233
	lb	37,937	37,530	38,312	37,622	37,212	37,982
Breakout Force** (§)	kN	203	202	216	195	194	207
	lb	45,788	45,479	48,572	43,941	43,632	46,510
Operating Weight*	kg	26 642	26 780	26 616	26 700	26 838	26 675
	lb	58,718	59,022	58,662	58,847	59,151	58,791

* Static tipping loads and operating weights shown are based on a machine configuration with Michelin 26.5R25 XHA2 L3 Radial tires, full fluids, operator, standard counterweight, cold start, roading fenders, Product Link, open differential axles (front/rear), power train guard, secondary steering, and sound suppression.

** Measured 102 mm (4") behind tip of cutting edge with bucket hinge pin as pivot point in accordance with SAE J732C.

*** Rock bucket specifications are given on Michelin 26.5R25 XLDD2 L5 Radial tires.

(§) Specifications and ratings conform to all applicable standards recommended by the Society of Automotive Engineers, including SAE Standard J732C governing loader ratings.

(ISO) Full compliance to ISO 14397-1 (2007) Sections 1 thru 6, which requires 2% verification between calculations and testing.

(Rigid Tire) Compliance to ISO 14397-1 (2007) Sections 1 thru 5.

Operating Specifications

Bucket Type		General Purpose – Fusion QC					
		Bolt-On Edges	Teeth and Segments	Teeth	Bolt-On Edges	Teeth and Segments	Teeth
Capacity – Rated (§)	m ³	4.80	4.80	4.60	5.00	5.00	4.80
	yd ³	6.28	6.28	6.02	6.54	6.54	6.28
Capacity – Struck (§)	m ³	4.10	4.10	3.90	4.30	4.30	4.10
	yd ³	5.36	5.36	5.10	5.62	5.62	5.36
Width (§)	mm	3220	3271	3271	3220	3271	3271
	ft/in	10'6"	10'8"	10'8"	10'6"	10'8"	10'8"
Dump Clearance at Maximum Lift and 45° Discharge (§)	mm	3130	2975	2975	3106	2951	2951
	ft/in	10'3"	9'9"	9'9"	10'2"	9'8"	9'8"
Reach at Maximum Lift and 45° Discharge (§)	mm	1419	1555	1555	1440	1576	1576
	ft/in	4'7"	5'1"	5'1"	4'8"	5'2"	5'2"
Reach at Level Lift Arm and Bucket Level (§)	mm	3085	3290	3290	3117	3322	3322
	ft/in	10'1"	10'9"	10'9"	10'2"	10'10"	10'10"
Digging Depth (§)	mm	103	103	73	103	103	73
	ft/in	4"	4"	2.8"	4"	4"	2.8"
Overall Length	mm	9259	9483	9483	9291	9515	9515
	ft/in	30'5"	31'2"	31'2"	30'6"	31'3"	31'3"
Overall Height with Bucket at Maximum Lift	mm	6270	6270	6270	6296	6296	6296
	ft/in	20'7"	20'7"	20'7"	20'8"	20'8"	20'8"
Loader Clearance Circle with Bucket at Carry Position (§)	mm	14 991	15 174	15 174	15 009	15 193	15 193
	ft/in	49'3"	49'10"	49'10"	49'3"	49'11"	49'11"
Static Tipping Load, Straight (ISO)*	kg	18 105	17 922	18 271	17 986	17 802	18 150
	lb	39,903	39,500	40,270	39,642	39,237	40,003
Static Tipping Load, Straight (Rigid Tire)*	kg	19 423	19 236	19 602	19 306	19 119	19 483
	lb	42,808	42,396	43,203	42,552	42,138	42,941
Static Tipping Load, Articulated (ISO)*	kg	15 754	15 569	15 903	15 636	15 450	15 783
	lb	34,722	34,314	35,051	34,462	34,052	34,786
Static Tipping Load, Articulated (Rigid Tire)*	kg	17 068	16 881	17 230	16 953	16 766	17 112
	lb	37,619	37,207	37,975	37,366	36,952	37,716
Breakout Force** (§)	kN	190	189	201	186	185	196
	lb	42,897	42,588	45,348	41,881	41,572	44,224
Operating Weight*	kg	26 695	26 833	26 670	26 786	26 924	26 761
	lb	58,836	59,140	58,780	59,036	59,340	58,980

* Static tipping loads and operating weights shown are based on a machine configuration with Michelin 26.5R25 XHA2 L3 Radial tires, full fluids, operator, standard counterweight, cold start, roading fenders, Product Link, open differential axles (front/rear), power train guard, secondary steering, and sound suppression.

** Measured 102 mm (4") behind tip of cutting edge with bucket hinge pin as pivot point in accordance with SAE J732C.

*** Rock bucket specifications are given on Michelin 26.5R25 XLDD2 L5 Radial tires.

(§) Specifications and ratings conform to all applicable standards recommended by the Society of Automotive Engineers, including SAE Standard J732C governing loader ratings.

(ISO) Full compliance to ISO 14397-1 (2007) Sections 1 thru 6, which requires 2% verification between calculations and testing.

(Rigid Tire) Compliance to ISO 14397-1 (2007) Sections 1 thru 5.

972K Wheel Loader Specifications

Operating Specifications

Bucket Type		Material Handling – Pin On			Rock – Pin On***		
		Bolt-On Edges	Teeth and Segments	Teeth	Bolt-On Edges	Teeth and Segments	Teeth
Capacity – Rated (§)	m ³	4.60	4.60	4.40	3.60	3.60	3.40
	yd ³	6.02	6.02	5.75	4.71	4.71	4.45
Capacity – Struck (§)	m ³	3.90	3.90	3.70	3.10	3.10	2.90
	yd ³	5.10	5.10	4.84	4.05	4.05	3.79
Width (§)	mm	3220	3271	3271	3252	3252	3252
	ft/in	10'6"	10'8"	10'8"	10'8"	10'8"	10'8"
Dump Clearance at Maximum Lift and 45° Discharge (§)	mm	3120	2957	2957	3336	3248	3248
	ft/in	10'2"	9'8"	9'8"	10'11"	10'7"	10'7"
Reach at Maximum Lift and 45° Discharge (§)	mm	1286	1413	1413	1420	1528	1528
	ft/in	4'2"	4'7"	4'7"	4'7"	5'0"	5'0"
Reach at Level Lift Arm and Bucket Level (§)	mm	3014	3219	3219	2964	3104	3104
	ft/in	9'10"	10'6"	10'6"	9'8"	10'2"	10'2"
Digging Depth (§)	mm	103	103	73	44	44	4
	ft/in	4"	4"	2.8"	1.7"	1.7"	0.1"
Overall Length	mm	9188	9412	9412	9127	9272	9272
	ft/in	30'2"	30'11"	30'11"	30'0"	30'6"	30'6"
Overall Height with Bucket at Maximum Lift	mm	6162	6162	6162	6042	6042	6042
	ft/in	20'3"	20'3"	20'3"	19'10"	19'10"	19'10"
Loader Clearance Circle with Bucket at Carry Position (§)	mm	14 957	15 137	15 137	14 978	15 061	15 061
	ft/in	49'1"	49'8"	49'8"	49'2"	49'5"	49'5"
Static Tipping Load, Straight (ISO)*	kg	18 595	18 413	18 653	19 302	19 235	19 616
	lb	40,983	40,582	41,111	42,543	42,394	43,234
Static Tipping Load, Straight (Rigid Tire)*	kg	19 901	19 715	19 958	20 641	20 572	20 963
	lb	43,862	43,453	43,988	45,494	45,342	46,202
Static Tipping Load, Articulated (ISO)*	kg	16 235	16 051	16 274	16 872	16 804	17 167
	lb	35,782	35,376	35,869	37,187	37,036	37,837
Static Tipping Load, Articulated (Rigid Tire)*	kg	17 534	17 349	17 573	18 203	18 134	18 504
	lb	38,646	38,237	38,732	40,120	39,968	40,783
Breakout Force** (§)	kN	201	199	213	222	222	231
	lb	45,174	44,865	47,882	50,090	49,982	52,114
Operating Weight*	kg	26 279	26 417	26 253	26 934	26 985	26 760
	lb	57,918	58,222	57,862	59,361	59,473	58,977

* Static tipping loads and operating weights shown are based on a machine configuration with Michelin 26.5R25 XHA2 L3 Radial tires, full fluids, operator, standard counterweight, cold start, roading fenders, Product Link, open differential axles (front/rear), power train guard, secondary steering, and sound suppression.

** Measured 102 mm (4") behind tip of cutting edge with bucket hinge pin as pivot point in accordance with SAE J732C.

*** Rock bucket specifications are given on Michelin 26.5R25 XLDD2 L5 Radial tires.

(§) Specifications and ratings conform to all applicable standards recommended by the Society of Automotive Engineers, including SAE Standard J732C governing loader ratings.

(ISO) Full compliance to ISO 14397-1 (2007) Sections 1 thru 6, which requires 2% verification between calculations and testing.

(Rigid Tire) Compliance to ISO 14397-1 (2007) Sections 1 thru 5.

Operating Specifications

Bucket Type		Rock – Pin On***			Rock – Fusion QC***		
		Bolt-On Edges	Teeth and Segments	Teeth	Bolt-On Edges	Teeth and Segments	Teeth
Capacity – Rated (§)	m ³	4.00	4.00	3.80	3.60	3.60	3.40
	yd ³	5.23	5.23	4.97	4.71	4.71	4.45
Capacity – Struck (§)	m ³	3.50	3.50	3.30	3.10	3.10	2.90
	yd ³	4.58	4.58	4.32	4.05	4.05	3.79
Width (§)	mm	3252	3252	3252	3252	3252	3252
	ft/in	10'8"	10'8"	10'8"	10'8"	10'8"	10'8"
Dump Clearance at Maximum Lift and 45° Discharge (§)	mm	3233	3142	3142	3310	3222	3222
	ft/in	10'7"	10'3"	10'3"	10'10"	10'6"	10'6"
Reach at Maximum Lift and 45° Discharge (§)	mm	1463	1571	1571	1455	1563	1563
	ft/in	4'9"	5'1"	5'1"	4'9"	5'1"	5'1"
Reach at Level Lift Arm and Bucket Level (§)	mm	3073	3214	3214	3008	3147	3147
	ft/in	10'1"	10'6"	10'6"	9'10"	10'3"	10'3"
Digging Depth (§)	mm	44	44	44	44	44	4
	ft/in	1.7"	1.7"	1.7"	1.7"	1.7"	0.1"
Overall Length	mm	9236	9380	9380	9171	9315	9315
	ft/in	30'4"	30'10"	30'10"	30'2"	30'7"	30'7"
Overall Height with Bucket at Maximum Lift	mm	6159	6159	6159	6060	6060	6060
	ft/in	20'3"	20'3"	20'3"	19'11"	19'11"	19'11"
Loader Clearance Circle with Bucket at Carry Position (§)	mm	15 039	15 123	15 123	14 996	15 081	15 081
	ft/in	49'5"	49'8"	49'8"	49'3"	49'6"	49'6"
Static Tipping Load, Straight (ISO)*	kg	19 183	19 114	19 459	18 779	18 710	19 158
	lb	42,281	42,128	42,887	41,390	41,238	42,225
Static Tipping Load, Straight (Rigid Tire)*	kg	20 544	20 474	20 829	20 105	20 035	20 500
	lb	45,281	45,125	45,907	44,312	44,157	45,184
Static Tipping Load, Articulated (ISO)*	kg	16 744	16 674	17 016	16 368	16 299	16 730
	lb	36,905	36,750	37,503	36,076	35,923	36,873
Static Tipping Load, Articulated (Rigid Tire)*	kg	18 098	18 027	18 376	17 690	17 620	18 065
	lb	39,889	39,733	40,501	38,990	38,835	39,816
Breakout Force** (§)	kN	204	204	212	215	214	223
	lb	45,999	45,886	47,764	48,357	48,247	50,268
Operating Weight*	kg	27 081	27 132	26 907	27 326	27 378	27 153
	lb	59,685	59,797	59,301	60,225	60,339	59,844

* Static tipping loads and operating weights shown are based on a machine configuration with Michelin 26.5R25 XHA2 L3 Radial tires, full fluids, operator, standard counterweight, cold start, roading fenders, Product Link, open differential axles (front/rear), power train guard, secondary steering, and sound suppression.

** Measured 102 mm (4") behind tip of cutting edge with bucket hinge pin as pivot point in accordance with SAE J732C.

*** Rock bucket specifications are given on Michelin 26.5R25 XLDD2 L5 Radial tires.

(§) Specifications and ratings conform to all applicable standards recommended by the Society of Automotive Engineers, including SAE Standard J732C governing loader ratings.

(ISO) Full compliance to ISO 14397-1 (2007) Sections 1 thru 6, which requires 2% verification between calculations and testing.

(Rigid Tire) Compliance to ISO 14397-1 (2007) Sections 1 thru 5.

972K Wheel Loader Specifications

Operating Specifications

Bucket Type		Coal – Pin On	Coal – Fusion QC	High Lift Change in Specs
Edge Type		Bolt-On Edges	Bolt-On Edges	
Capacity – Rated (§)	m ³	7.10	7.10	
	yd ³	9.29	9.29	
Capacity – Struck (§)	m ³	6.20	6.20	
	yd ³	8.11	8.11	
Width (§)	mm	3447	3447	
	ft/in	11'3"	11'3"	
Dump Clearance at Maximum Lift and 45° Discharge (§)	mm	2842	2819	335
	ft/in	9'3"	9'2"	1'1"
Reach at Maximum Lift and 45° Discharge (§)	mm	1544	1584	23
	ft/in	5'0"	5'2"	1"
Reach at Level Lift Arm and Bucket Level (§)	mm	3393	3438	273
	ft/in	11'1"	11'3"	0'10"
Digging Depth (§)	mm	117	105	-4
	ft/in	4.6"	4.1"	-0.1"
Overall Length	mm	9578	9614	336
	ft/in	31'6"	31'7"	1'2"
Overall Height with Bucket at Maximum Lift	mm	6546	6581	336
	ft/in	21'6"	21'8"	1'2"
Loader Clearance Circle with Bucket at Carry Position (§)	mm	15 385	15 401	332
	ft/in	50'6"	50'7"	1'2"
Static Tipping Load, Straight (ISO)*	kg	17 394	16 779	-1558
	lb	38,337	36,983	-3,434
Static Tipping Load, Straight (Rigid Tire)*	kg	18 728	18 106	-1721
	lb	41,277	39,906	-3,794
Static Tipping Load, Articulated (ISO)*	kg	15 072	14 465	-1391
	lb	33,220	31,882	-3,066
Static Tipping Load, Articulated (Rigid Tire)*	kg	16 407	15 797	-1568
	lb	36,161	34,817	-3,457
Breakout Force** (§)	kN	154	149	-5
	lb	34,604	33,479	-1,327
Operating Weight*	kg	26 946	27 506	85
	lb	59,387	60,622	186

* Static tipping loads and operating weights shown are based on a machine configuration with Michelin 26.5R25 XHA2 L3 Radial tires, full fluids, operator, standard counterweight, cold start, roading fenders, Product Link, open differential axles (front/rear), power train guard, secondary steering, and sound suppression.

** Measured 102 mm (4") behind tip of cutting edge with bucket hinge pin as pivot point in accordance with SAE J732C.

*** Rock bucket specifications are given on Michelin 26.5R25 XLDD2 L5 Radial tires.

(§) Specifications and ratings conform to all applicable standards recommended by the Society of Automotive Engineers, including SAE Standard J732C governing loader ratings.

(ISO) Full compliance to ISO 14397-1 (2007) Sections 1 thru 6, which requires 2% verification between calculations and testing.

(Rigid Tire) Compliance to ISO 14397-1 (2007) Sections 1 thru 5.

Extended Capacity Operating Specifications

Bucket Type		General Purpose – Pin On					
		Bolt-On Edges	Teeth and Segments	Teeth	Bolt-On Edges	Teeth and Segments	Teeth
Capacity – Rated (§)	m ³	4.60	4.60	4.40	4.90	4.90	4.70
	yd ³	6.02	6.02	5.75	6.41	6.41	6.15
Capacity – Struck (§)	m ³	4.05	4.05	3.90	4.20	4.20	4.00
	yd ³	5.30	5.30	5.10	5.49	5.49	5.23
Width (§)	mm	3220	3271	3271	3220	3271	3271
	ft/in	10'6"	10'8"	10'8"	10'6"	10'8"	10'8"
Dump Clearance at Maximum Lift and 45° Discharge (§)	mm	2978	2824	2824	2920	2765	2765
	ft/in	9'9"	9'3"	9'3"	9'6"	9'0"	9'0"
Reach at Maximum Lift and 45° Discharge (§)	mm	1400	1537	1537	1448	1584	1584
	ft/in	4'7"	5'0"	5'0"	4'9"	5'2"	5'2"
Reach at Level Lift Arm and Bucket Level (§)	mm	2857	3062	3062	2933	3138	3138
	ft/in	9'4"	10'0"	10'0"	9'7"	10'3"	10'3"
Digging Depth (§)	mm	123	123	93	123	123	93
	ft/in	4.8"	4.8"	3.6"	4.8"	4.8"	3.6"
Overall Length	mm	8996	9221	9221	9072	9297	9297
	ft/in	29'7"	30'4"	30'4"	29'10"	30'7"	30'7"
Overall Height with Bucket at Maximum Lift	mm	5875	5875	5875	6095	6095	6095
	ft/in	19'4"	19'4"	19'4"	20'0"	20'0"	20'0"
Loader Clearance Circle with Bucket at Carry Position (§)	mm	14 787	14 961	14 961	14 827	15 001	15 001
	ft/in	48'7"	49'1"	49'1"	48'8"	49'3"	49'3"
Static Tipping Load, Straight (ISO)*	kg	20 204	20 021	20 388	20 052	19 867	20 098
	lb	44,531	44,127	44,936	44,194	43,787	44,296
Static Tipping Load, Straight (Rigid Tire)*	kg	21 762	21 574	21 959	21 624	21 434	21 667
	lb	47,964	47,549	48,397	47,660	47,241	47,755
Static Tipping Load, Articulated (ISO)*	kg	17 668	17 482	17 836	17 520	17 333	17 546
	lb	38,940	38,531	39,312	38,615	38,202	38,672
Static Tipping Load, Articulated (Rigid Tire)*	kg	19 203	19 015	19 384	19 071	18 881	19 094
	lb	42,325	41,910	42,722	42,032	41,614	42,085
Breakout Force** (§)	kN	215	214	228	204	202	215
	lb	48,470	48,095	51,358	45,923	45,550	48,516
Operating Weight*	kg	26 062	26 200	26 037	26 185	26 323	26 160
	lb	57,440	57,744	57,384	57,712	58,016	57,656

* Static tipping loads and operating weights shown are based on a machine configuration with Michelin 26.5R25 XHA2 L3 Radial tires, full fluids, operator, standard counterweight, cold start, roading fenders, Product Link, open differential axles (front/rear), power train guard, secondary steering, and sound suppression.

** Measured 102 mm (4") behind tip of cutting edge with bucket hinge pin as pivot point in accordance with SAE J732C.

*** Rock bucket specifications are given on Michelin 26.5R25 XLDD2 L5 Radial tires.

(§) Specifications and ratings conform to all applicable standards recommended by the Society of Automotive Engineers, including SAE Standard J732C governing loader ratings.

(ISO) Full compliance to ISO 14397-1 (2007) Sections 1 thru 6, which requires 2% verification between calculations and testing.

(Rigid Tire) Compliance to ISO 14397-1 (2007) Sections 1 thru 5.

972K Wheel Loader Specifications

Extended Capacity Operating Specifications

Bucket Type		General Purpose – Fusion QC					
		Bolt-On Edges	Teeth and Segments	Teeth	Bolt-On Edges	Teeth and Segments	Teeth
Capacity – Rated (§)	m ³	4.60	4.60	4.40	4.90	4.90	4.70
	yd ³	6.02	6.02	5.75	6.41	6.41	6.15
Capacity – Struck (§)	m ³	4.05	4.05	3.90	4.20	4.20	4.00
	yd ³	5.30	5.30	5.10	5.49	5.49	5.23
Width (§)	mm	3220	3271	3271	3220	3271	3271
	ft/in	10'6"	10'8"	10'8"	10'6"	10'8"	10'8"
Dump Clearance at Maximum Lift and 45° Discharge (§)	mm	2948	2794	2794	2899	2744	2744
	ft/in	9'8"	9'2"	9'2"	9'6"	9'0"	9'0"
Reach at Maximum Lift and 45° Discharge (§)	mm	1436	1573	1573	1484	1621	1621
	ft/in	4'8"	5'1"	5'1"	4'10"	5'3"	5'3"
Reach at Level Lift Arm and Bucket Level (§)	mm	2903	3108	3108	2975	3180	3180
	ft/in	9'6"	10'2"	10'2"	9'9"	10'5"	10'5"
Digging Depth (§)	mm	122	122	92	115	115	85
	ft/in	4.8"	4.8"	3.6"	4.5"	4.5"	3.3"
Overall Length	mm	9041	9267	9267	9108	9333	9333
	ft/in	29'8"	30'5"	30'5"	29'11"	30'8"	30'8"
Overall Height with Bucket at Maximum Lift	mm	6039	6039	6039	6126	6126	6126
	ft/in	19'10"	19'10"	19'10"	20'2"	20'2"	20'2"
Loader Clearance Circle with Bucket at Carry Position (§)	mm	14 804	14 981	14 981	14 837	15 015	15 015
	ft/in	48'7"	49'2"	49'2"	48'9"	49'4"	49'4"
Static Tipping Load, Straight (ISO)*	kg	19 674	19 491	19 844	19 574	19 389	19 752
	lb	43,362	42,959	43,738	43,141	42,734	43,534
Static Tipping Load, Straight (Rigid Tire)*	kg	21 217	21 029	21 404	21 141	20 952	21 335
	lb	46,763	46,350	47,176	46,596	46,178	47,023
Static Tipping Load, Articulated (ISO)*	kg	17 155	16 969	17 308	17 052	16 865	17 213
	lb	37,809	37,400	38,147	37,584	37,171	37,937
Static Tipping Load, Articulated (Rigid Tire)*	kg	18 681	18 493	18 850	18 603	18 413	18 777
	lb	41,173	40,759	41,545	41,001	40,583	41,385
Breakout Force** (§)	kN	208	207	220	198	196	209
	lb	46,886	46,513	49,589	44,570	44,204	47,022
Operating Weight*	kg	26 508	26 646	26 483	26 598	26 736	26 573
	lb	58,424	58,728	58,368	58,622	58,926	58,567

* Static tipping loads and operating weights shown are based on a machine configuration with Michelin 26.5R25 XHA2 L3 Radial tires, full fluids, operator, standard counterweight, cold start, roading fenders, Product Link, open differential axles (front/rear), power train guard, secondary steering, and sound suppression.

** Measured 102 mm (4") behind tip of cutting edge with bucket hinge pin as pivot point in accordance with SAE J732C.

*** Rock bucket specifications are given on Michelin 26.5R25 XLDD2 L5 Radial tires.

(§) Specifications and ratings conform to all applicable standards recommended by the Society of Automotive Engineers, including SAE Standard J732C governing loader ratings.

(ISO) Full compliance to ISO 14397-1 (2007) Sections 1 thru 6, which requires 2% verification between calculations and testing.

(Rigid Tire) Compliance to ISO 14397-1 (2007) Sections 1 thru 5.

Bucket Selection Chart

Material Density		kg/m ³	700	800	900	1000	1100	1200	1300	1400	1500	1600	1700	1800	1900	2000	2100	2200	2300	2400	2500			
Standard Linkage	Pin On	General Purpose	4.20 m ³ (5.49 yd ³)											4.83 m ³ (6.32 yd ³)							4.20 m ³ (5.49 yd ³)			
			4.40 m ³ (5.75 yd ³)												5.06 m ³ (6.62 yd ³)							4.40 m ³ (5.75 yd ³)		
			4.60 m ³ (6.02 yd ³)													5.29 m ³ (6.92 yd ³)							4.60 m ³ (6.02 yd ³)	
			4.80 m ³ (6.28 yd ³)													5.52 m ³ (7.22 yd ³)							4.80 m ³ (6.28 yd ³)	
			5.00 m ³ (6.54 yd ³)													5.75 m ³ (7.52 yd ³)							5.00 m ³ (6.54 yd ³)	
	Fusion OC	General Purpose	4.20 m ³ (5.49 yd ³)																					
			4.40 m ³ (5.75 yd ³)																					
			4.60 m ³ (6.02 yd ³)																					
			4.80 m ³ (6.28 yd ³)																					
			5.00 m ³ (6.54 yd ³)																					
Material Handling	General Purpose	4.20 m ³ (5.49 yd ³)																						
		4.40 m ³ (5.75 yd ³)																						
		4.60 m ³ (6.02 yd ³)																						
		4.80 m ³ (6.28 yd ³)																						
		5.00 m ³ (6.54 yd ³)																						
Material Handling	Rock	4.60 m ³ (6.02 yd ³)																						
		3.60 m ³ (4.71 yd ³)																						
		4.00 m ³ (5.23 yd ³)																						
		4.20 m ³ (5.49 yd ³)																						
		4.40 m ³ (5.75 yd ³)																						
Material Handling	Coal	7.10 m ³ (9.29 yd ³)																						
		8.17 m ³ (10.69 yd ³)																						
		7.10 m ³ (9.29 yd ³)																						
		4.20 m ³ (5.49 yd ³)																						
		4.40 m ³ (5.75 yd ³)																						
Material Handling	General Purpose	4.20 m ³ (5.49 yd ³)																						
		4.40 m ³ (5.75 yd ³)																						
		4.60 m ³ (6.02 yd ³)																						
		4.80 m ³ (6.28 yd ³)																						
		5.00 m ³ (6.54 yd ³)																						
Material Handling	Rock	4.60 m ³ (6.02 yd ³)																						
		3.60 m ³ (4.71 yd ³)																						
		4.00 m ³ (5.23 yd ³)																						
		4.20 m ³ (5.49 yd ³)																						
		4.40 m ³ (5.75 yd ³)																						
Material Handling	Coal	7.10 m ³ (9.29 yd ³)																						
		8.17 m ³ (10.69 yd ³)																						
		7.10 m ³ (9.29 yd ³)																						
		4.20 m ³ (5.49 yd ³)																						
		4.40 m ³ (5.75 yd ³)																						
Material Density	lb/yd ³	1,180	1,348	1,517	1,685	1,854	2,022	2,191	2,359	2,528	2,696	2,865	3,033	3,202	3,370	3,539	3,707	3,876	4,044	4,213				
Bucket Density																								

All buckets are showing Bolt-On Edges.
 Material Handling buckets are flat floor buckets.

972K Wheel Loader Specifications

Bucket Selection Chart

Material Density		kg/m ³	700	800	900	1000	1100	1200	1300	1400	1500	1600	1700	1800	1900	2000	2100	2200	2300	2400	2500					
High Lift Linkage	Pin On	General Purpose	4.20 m ³ (5.49 yd ³)									4.83 m ³ (6.32 yd ³)			4.20 m ³ (5.49 yd ³)											
			4.40 m ³ (5.75 yd ³)									5.06 m ³ (6.62 yd ³)			4.40 m ³ (5.75 yd ³)											
			4.60 m ³ (6.02 yd ³)									5.29 m ³ (6.92 yd ³)			4.60 m ³ (6.02 yd ³)											
			4.80 m ³ (6.28 yd ³)									5.52 m ³ (7.22 yd ³)			4.80 m ³ (6.28 yd ³)											
			5.00 m ³ (6.54 yd ³)									5.75 m ³ (7.52 yd ³)			5.00 m ³ (6.54 yd ³)											
	Material Handling	4.60 m ³ (6.02 yd ³)									5.29 m ³ (6.92 yd ³)			4.60 m ³ (6.02 yd ³)												
		Rock	3.60 m ³ (4.71 yd ³)									4.14 m ³ (5.42 yd ³)					3.42 m ³ (4.47 yd ³)									
			4.00 m ³ (5.23 yd ³)									4.60 m ³ (6.02 yd ³)					3.80 m ³ (4.97 yd ³)									
	Coal	7.10 m ³ (9.29 yd ³)	8.17 m ³ (10.69 yd ³)						7.10 m ³ (9.29 yd ³)																	
	Fusion OC	General Purpose	4.20 m ³ (5.49 yd ³)										4.83 m ³ (6.32 yd ³)			4.20 m ³ (5.49 yd ³)										
			4.40 m ³ (5.75 yd ³)										5.06 m ³ (6.62 yd ³)			4.40 m ³ (5.75 yd ³)										
			4.60 m ³ (6.02 yd ³)										5.29 m ³ (6.92 yd ³)			4.60 m ³ (6.02 yd ³)										
4.80 m ³ (6.28 yd ³)												5.52 m ³ (7.22 yd ³)			4.80 m ³ (6.28 yd ³)											
5.00 m ³ (6.54 yd ³)												5.75 m ³ (7.52 yd ³)			5.00 m ³ (6.54 yd ³)											
Rock		3.60 m ³ (4.71 yd ³)										4.14 m ³ (5.42 yd ³)					3.42 m ³ (4.47 yd ³)									
Coal	7.10 m ³ (9.29 yd ³)	8.17 m ³ (10.69 yd ³)						7.10 m ³ (9.29 yd ³)																		
Material Density	lb/yd ³	1,180	1,348	1,517	1,685	1,854	2,022	2,191	2,359	2,528	2,696	2,865	3,033	3,202	3,370	3,539	3,707	3,876	4,044	4,213						
Bucket Density																										

All buckets are showing Bolt-On Edges.
Material Handling buckets are flat floor buckets.

Bucket Selection Chart

Material Density		kg/m ³	700	800	900	1000	1100	1200	1300	1400	1500	1600	1700	1800	1900	2000	2100	2200	2300	2400	2500					
Extended Capacity Linkage Pin On	General Purpose	4.60 m ³ (6.02 yd ³)											5.29 m ³ (6.92 yd ³)													
	General Purpose	4.90 m ³ (6.41 yd ³)											5.64 m ³ (7.38 yd ³)				4.90 m ³ (6.41 yd ³)									
Extended Capacity Linkage Fusion DC	General Purpose	4.60 m ³ (6.02 yd ³)											5.29 m ³ (6.92 yd ³)													
	General Purpose	4.90 m ³ (6.41 yd ³)											5.64 m ³ (7.38 yd ³)				4.90 m ³ (6.41 yd ³)									
Material Density		lb/yd ³	1,180	1,348	1,517	1,685	1,854	2,022	2,191	2,359	2,528	2,696	2,865	3,033	3,202	3,370	3,539	3,707	3,876	4,044	4,213					
Bucket Density																										
115% 110% 105% 100% 95%																										

All buckets are showing Bolt-On Edges.
Material Handling buckets are flat floor buckets.

Bucket Fill Factors

(as a % of ISO Rated Capacity)

Loose Material	Performance Series Bucket
Earth/Clay	115
Sand and Gravel	115
Aggregate:	
25-76 mm (1 to 3 in)	110
19 mm (0.75 in) and smaller	105
Rock	100

972K Standard Equipment

Standard equipment may vary. Consult your Cat dealer for details.

POWER TRAIN

Brakes, full hydraulic enclosed wet-disc with Integrated Braking System (IBS)
Brake wear indicators
Diesel Particulate Filter (DPF)
Engine, Cat 9.3 meets Tier 4 Interim/Stage IIIB emission standards
Fan, radiator, electronically controlled, hydraulically driven, temperature sensing, on demand
Fuel Management System (FMS)
Fuel priming pump (electric)
Fuel/water separator
Guard, vandalism
Precleaner, engine air intake
Radiator, unit core (6 fpi) with ATAAC
Switch, transmission neutralizer lockout
Torque converter, free wheel stator
Transmission, automatic planetary power shift (4F/4R)
Variable Shift Control (VSC)

ELECTRICAL

Alarm, back-up
Alternator, 150-amp brushless
Batteries, (2) maintenance free 1,400 CCA
Ignition key; start/stop switch
Lighting system:

- Four halogen work lights
- Two halogen roading lights (with signals)
- Two halogen rear vision lights (hood mounted)

Main disconnect switch
Receptacle start (cables not included)
Starter, electric, heavy duty
Starting and charging system (24-volt)

OPERATOR ENVIRONMENT

Air conditioner, heater, and defroster (auto temp and fan)
Beverage holders (2) with storage compartment for cell phone/MP3 player
Bucket/Work Tool function lockout
Cab, pressurized and sound suppressed, (ROPS/FOPS) radio ready (entertainment) includes antenna, speakers and converter (12-volt 10-amp)
Camera, rearview
Coat hook (2)
EH controls, lift and tilt function
EH parking brake
Computerized monitoring system
Instrumentation, gauges:

- Digital gear range indicator
- DPF soot loading percent
- Engine coolant temperature
- Fuel level
- Hydraulic oil temperature
- Speedometer/tachometer
- Transmission oil temperature

Instrumentation, warning indicators:

- Axle oil temperature
- Battery voltage hi/low
- Engine air filter restriction
- Engine intake manifold temperature
- Engine oil pressure
- Fuel level and pressure hi/low
- Hydraulic oil filter restriction
- Hydraulic oil low
- Parking brake
- Primary steering oil pressure
- Service brake oil pressure
- Transmission filter bypass

Horn, electric
Light, two dome (cab)
Mirrors, rearview external (includes spot mirrors)
Post mounted membrane switch keypads
Receptacle, 12-volt
Seat, Cat Comfort (cloth) air suspension
Seat belt, retractable, 51 mm (2") wide
Steering, EH joystick, speed sensing with force feedback
Sun visor, front
Wet-arm wipers/washers front and rear

- Intermittent front wiper

Window, sliding (left and right sides)
Viscous mounts

TIRES

A tire must be selected from the mandatory attachments section. Base machine price includes an allowance.

FLUIDS

Premixed 50% concentration of Extended Life Coolant with freeze protection to -34°C (-29°F)

OTHER STANDARD EQUIPMENT

Auto idle shutdown
Couplings, Cat O-ring face seal
Ecology drains for engine, transmission, axles, and hydraulics
Ether aid
Fenders, steel front with mud-flap/rear with extension
Filters:

- Fuel, primary/secondary
- Engine air, primary/secondary
- Engine oil
- Hydraulic oil
- Transmission

Fuel cooler
Grease zerks
Grill, airborne debris
Hitch, drawbar with pin
Hood, non-metallic power tilting with rear clamshell
Hoses, Cat XT
Hydraulic oil cooler (swing out)
Hydraulic system, load sensing
Kickout, lift and tilt, automatic (adjustable in cab)
Linkage, Z-bar, cast cross-tube/tilt lever
Oil sampling valves
Platform, window washing
Product Link
Remote diagnostic pressure taps
Ride control, 2V
Service center (electrical and hydraulic)
Sight gauges: engine coolant, hydraulic oil, and transmission oil level
Steering, load sensing
Toolbox
Vandalism protection caplocks

Optional equipment may vary. Consult your Cat dealer for details.

Power Train

- Differentials
 - Open, front or rear
 - Limited slip, front
 - Limited slip, front and rear
- Extreme temperature seals
- Seal guards
- Axle oil cooler

Hydraulics arrangement, 3 valve

Cold start package (120V)

Comfort package

Work lighting package, halogen

Work lighting package, HID

Industrial package

Steel mill package

Short lift, 2 valve

Short lift, 3 valve

High lift, 2 valve

High lift, 3 valve

Quick coupler

Quick coupler ready, 2V

Quick coupler ready, 3V

Bucket and work tool options (contact Cat

Work Tools)

Lights, signal LED

Product Link, satellite

Control, aggregate autodig

Joystick, 2 valve

Joystick, 3 valve

Payload control system

Printer, payload CNTL system

Radio, AM/FM CD/MP3 player

Radio, CB (ready)

Radio, Satellite – XM (Bluetooth capable)

Radio, Satellite – Sirius (Bluetooth capable)

Steering secondary

Filter, carbon fresh air

Seat belt, 76 mm (3") wide

Sun visor, rear

Security system, machine

Cooling, high ambient

Guard, power train

Guard, front window

Guard, complete cab

Guard, front window (Logger)

Autolube

Fenders, roading with fender extensions front/rear

Precleaner, HVAC

Precleaner, turbine

Precleaner, turbine/trash

Oil change system, high speed

Sound suppression (low) NACD

Fan, variable pitch

Antifreeze, –50° C (–58° F)

EH steering wheel (availability TBD)

972K Wheel Loader

For more complete information on Cat products, dealer services, and industry solutions, visit us on the web at www.cat.com

© 2011 Caterpillar Inc.
All rights reserved

AEHQ6226-01 (07-2011)

Materials and specifications are subject to change without notice. Featured machines in photos may include additional equipment. See your Cat dealer for available options.

CAT, CATERPILLAR, SAFETY.CAT.COM, their respective logos, "Caterpillar Yellow" and the "Power Edge" trade dress, as well as corporate and product identity used herein, are trademarks of Caterpillar and may not be used without permission.

