



Cat[®] CS11 GC

VIBRATORY SOIL COMPACTOR

FEATURES:

The Cat[®] CS11 GC features a smooth drum ideal for granular soil applications. A padfoot shell kit is available for cohesive soil applications.

- **Superior compaction performance** due to high weight at the drum and high amplitude.
- **Easy-to-use and comfortable** with simple controls within easy reach. Outstanding visibility to the front and rear of machine.
- **Proven, exclusive, world-class Cat features** including the ultra-reliable pod-style vibratory system; the sealed-for-life, maintenance-free hitch bearing; and optional Cat Compaction Control.

- **Reliable Cat engine** provides ample power and consistent performance. Standard Eco-mode reduces fuel use during normal operation.
- **Simple maintenance** due to maintenance-free hitch bearings and extended maintenance intervals for vibratory system and hydraulic system, providing more uptime and lower maintenance costs.
- **Optional Cat Compaction Control technology** helps the operator determine when compaction has been completed to specification for greater productivity and uniform compaction quality. Scalable solution can be configured to meet needs.

Specifications

Engine - Powertrain

Engine Model	Cat C4.4	
Emissions	US EPA Tier 3/EU Stage IIIA/ equivalent	
Gross Power ISO 14396	83 kW	111.3 hp
Net Power - SAE J1349	78.5 kW	105.3 hp
Net Power - ISO 9249	79.4 kW	106.5 hp
Displacement	4.4 L	268.5 in ³
Stroke	127 mm	5 in
Bore	105 mm	4.1 in
Max. Travel Speed (Forward or Reverse)	11.2 km/h	6.9 mph
Theoretical Gradeability, no vibration*	55%	

Weights

Operating Weight w/ sun canopy	10 803 kg	23,817 lb
w/ weight kit	12 230 kg	26,963 lb
w/ oval padfoot shell kit	12 561 kg	27,692 lb
w/ square padfoot shell kit	12 720 kg	28,043 lb
w/ padfoot bumper, no shell	11 045 kg	24,350 lb
Weight at Drum w/ sun canopy	5988 kg	13,201 lb
w/ weight kit	7582 kg	16,716 lb
w/ oval padfoot shell kit	7624 kg	16,808 lb
w/ square padfoot shell kit	7783 kg	17,159 lb
w/ padfoot bumper, no shell	6109 kg	13,468 lb

Vibratory System Specifications

Nominal Amplitude - High	2.0 mm	0.079 in
Standard Frequency	30 Hz	1800 vpm
Eco-mode Frequency	28.6 Hz	1716 vpm
Nominal Amplitude - Low	1.00 mm	0.039 in
Frequency	33 Hz	1980 vpm
Eco-mode Frequency	31.5 Hz	1890 vpm
Centrifugal Force		
Maximum	250 kN	56,200 lb
Minimum	149 kN	33,500 lb
Static Linear Load		
w/ sun canopy	28.1 kg/cm	157.4 lbs/in
w/ sun canopy, weight kit	35.5 kg/cm	198.8 lbs/in
w/ sun canopy, shell bumper, no shell	28.6 kg/cm	160.2 lbs/in

Service Refill Capacities

Fuel Tank (total capacity)	248 L	65.5 gal
Cooling System	18.5 L	4.9 gal
Engine Oil w/ Filter	9.5 L	2.5 gal
Eccentric Weight Housings (combined)	26 L	6.9 gal
Axle and Final Drives	10.1 L	2.7 gal
Hydraulic Tank (service refill)	23 L	6 gal

* Actual gradeability may vary based on site conditions and machine configuration. Refer to the Operation and Maintenance Manual for more information.



CS11 GC Vibratory Soil Compactor

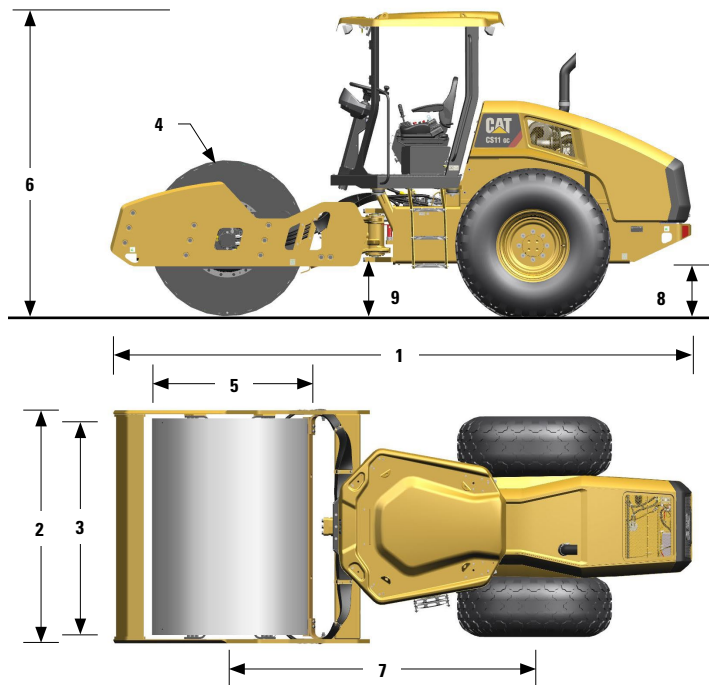

Dimensions

1 Overall Length	5.70 m	18.71 ft
2 Overall Width	2.30 m	7.53 ft
3 Drum Width	2134 mm	84 in
4 Drum Shell Thickness	25 mm	0.98 in
5 Drum Diameter	1535 mm	60.4 in
6 Maximum Overall Height	2.99 m	9.8 ft
with Padfoot Shell Kit option	3.09 m	10.1 ft
7 Wheelbase	3.00 m	9.8 ft
8 Ground Clearance	518 mm	20.4 in
9 Curb Clearance	492 mm	19.4 in
Inside Turning Radius	3.86 m	12.7 ft
Hitch Articulation Angle	34°	
Hitch Oscillation Angle	15°	

Optional Padfoot Shell Kit Specifications

Number of Pads	120	
Pad Height, oval pads	90 mm	3.5 in
Pad Face Area, oval pads	63.5 cm ²	9.8 in ²
Pad Height, square pads	90 mm	3.5 in
Pad Face Area, square pads	105.6 cm ²	16.4 in ²
Number of Chevrons	16	

STANDARD EQUIPMENT *Varies by market- contact your Dealer for specifics.*

ELECTRICAL

- 12-volt Electrical System
- 120-ampere Alternator
- 900 Cold-cranking Amps Battery Capacity

OPERATOR ENVIRONMENT

- Sun Canopy with Platform Handrails/Guardrails
- Vinyl Adjustable Seat, Seat Belt
- Steering Wheel Console with gauges and/or audible warning alarm for: *Hydraulic oil temperature, Engine oil pressure, Engine coolant temperature, Alternator charge, Fuel level, Service hour meter, Engine RPM, Optional Cat Compaction Control*
- Adjustable Tilting Steering Column
- 12-volt Power Outlet
- Floor Mat
- Interior Rear View Mirror
- Horn, Backup Alarm

POWERTRAIN

- Cat® C4.4 Diesel Engine, 4-cylinder
- Propel Pump
- Dual Fuel Filters, Water Separator, Electronic Priming Pump, Water Indicator
- Radiator/Hydraulic Oil Cooler, Charge Air Cooler
- Dual Braking System
- Two-speed Hydrostatic Transmission

VIBRATORY SYSTEM

- Smooth Drum, Adjustable Steel Scraper
- Dual Amplitude, Dual Frequency
- Pod-Style Eccentric Weight System
- Auto-vibe Function

OTHER

- Sight Gauges for Hydraulic Oil Level and Radiator Coolant Level
- Cat ToughGuard™ Hose
- S-O-SSM Sampling Valves, Engine Oil, Hydraulic Oil and Coolant
- Product Link™

OPTIONAL EQUIPMENT

- Padfoot Shell Kit (oval or square pad)
- Rotating Beacon
- Polyurethane Drum Scrapers
- Additional Steel Drum Scraper
- High Ambient Temperature Oil Factory Fill
- Cat Compaction Control, Machine Drive Power or CMV or Both
- SBAS GNSS Mapping for Cat Compaction Control (RTK available)
- Machine-to-Machine Communication for Cat Compaction Control
- Upgraded LED Light Package
- Flotation Tread or Lug Tread Tires
- Transmission Guard
- Side Mounted Rear View Mirrors
- Sound Reduction Kit
- XT Weight Kit
- Sun/Debris Shields

For more complete information on Cat products, dealer services, and industry solutions, visit us on the web at www.cat.com

QEHQ2428 (08/18)

Materials and specifications are subject to change without notice. Featured machines in photos may include additional equipment.

©2018 Caterpillar Inc.
All Rights Reserved.

CAT, CATERPILLAR, ACERT, BUILT FOR IT, their respective logos, "Caterpillar Yellow" and the "Power Edge" trade dress, as well as corporate and product identity used herein, are trademarks of Caterpillar and may not be used without permission.

Product ID: CS11 GC

